

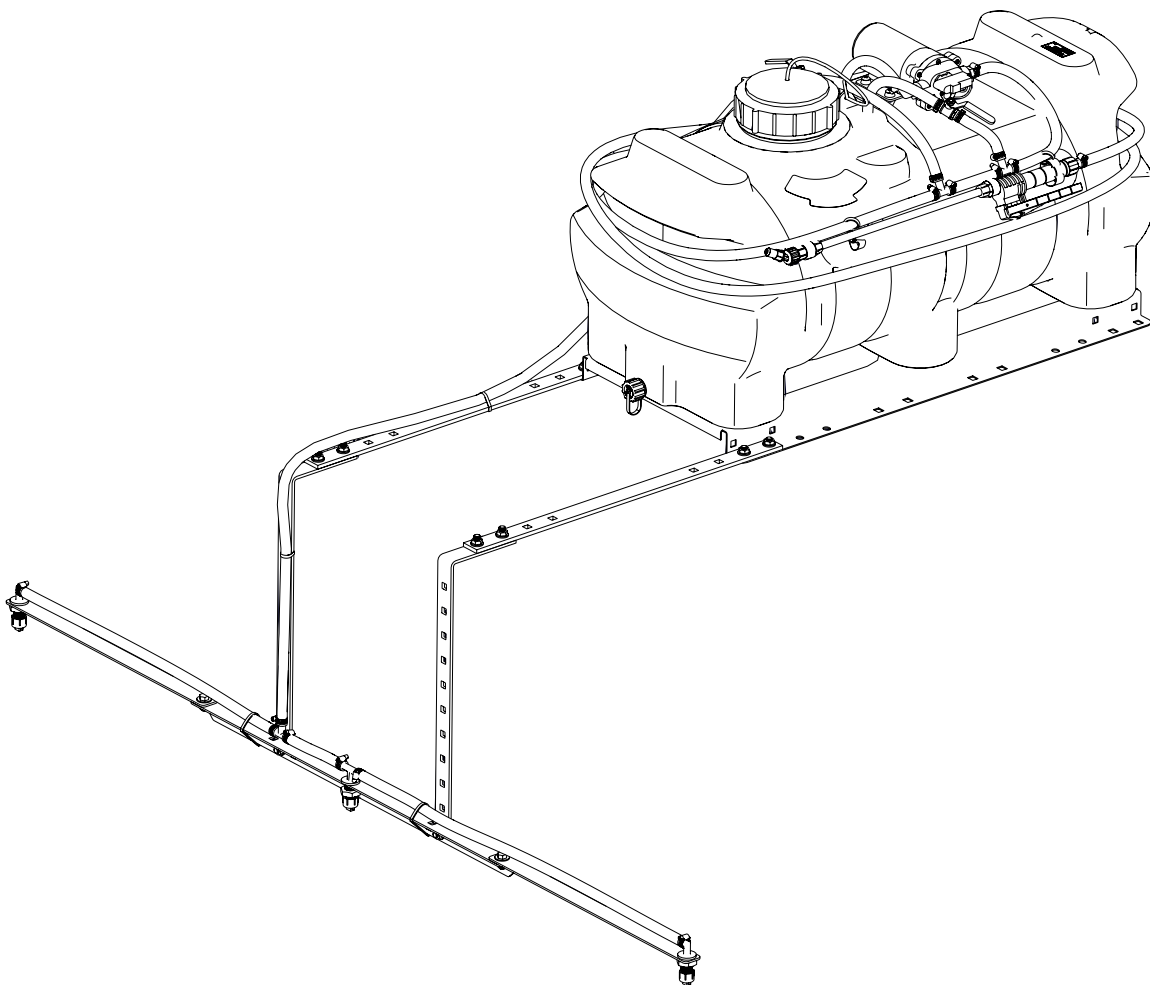

Owner's Manual

25 Gallon Skid Sprayer Model LGX25-2



Manufactured by PBZ LLC
A Paul B Zimmerman Inc. Company
www.CropCareEquipment.com

Form: LGX25-2OM
Rev. C Date: 6/22

Table Of Contents

Identification of Machine	2	Routine Maintenance.....	11-12
Specifications.....	2	Winterizing your Sprayer	12
Introduction	3	Troubleshooting	13
Safety	3	Breakdowns and Parts Lists	14-16
Signal Words.....	3	Base Unit Breakdown	14
General Guidelines.....	4	Base Unit Parts List.....	15
Before Operation	5	Pump Breakdown & Parts List	16
During Operation	5	CropCare® Limited Warranty	17
Following Operation	5	Ordering Parts	17
Pump Safety Precautions.....	5		
Installation	6		
Mounting the Skid Sprayer	6		
Wiring Harness	6		
Calibrating the Sprayer.....	7		
1. Calculating the Speed	7		
2. Application Rate Charts.....	8		
Boom Application Rate Chart	8		
Operating Instructions	9		
Spraying with the Boom	9-10		
Spraying with the Spray Gun	10		
Following Operation	11		
Maintenance Instructions	11-12		

Identification of Machine

- Model #'s: LGX25-2
- The model number and revision identification decal is located on top of the tank .

Specifications

25 gallon LGX Skid Sprayer

Tank capacity 25 gal
Min power supply 12 volt / 8 amp
Wiring harness length 8'

Pump:

Type Diaphragm pump
Manufacturer Remco®
Max pressure 60 psi
Max flow rate 2.2 gpm

Sprayer:

Spraying width (Boom) 120"
Hose length (Handgun) 15'

Weight:

Base unit (empty) 40 lbs
Base unit (full) 250 lbs

Introduction

Please read and understand this manual and its instructions and warnings completely before operating the sprayer.

- Familiarize yourself and other operators with the sprayer's components and how all parts are operated.
- Read and understand the chemical manufacturer's labels, warnings, and instructions.
- Know and fulfill all state pesticide applicator license requirements.
- Contact your authorized CropCare® Dealer for help interpreting the owners manual.
- Read and follow ALL of the chemical manufacturer's labels, warnings, and instructions about chemical usage! A material safety data sheet (MSDS) should be provided by the chemical manufacturer. CropCare® is not liable for misuse or mishandling of chemicals before spraying, during spraying, and after spraying.

Safety

Safety Alert Symbol

-The safety alert symbol for safety signs & decals that contain one of the three signal words (DANGER, WARNING, & CAUTION) will appear as shown in Figure 1.



Figure 1: Safety Alert Symbol

Signal Words

-There are three signal words; DANGER, WARNING, and CAUTION. The signal words bring attention to the existence and relative seriousness of a hazard.

- **DANGER:** The signal word DANGER indicates an imminently hazardous situation which, if not avoided, will result in death or serious injury
- **WARNING:** The signal word WARNING indicates a potentially hazardous situation which, if not avoided, could result in death or serious injury.
- **CAUTION:** The signal word CAUTION indicates a potentially hazardous situation which, if not avoided, may result in minor or moderate injury.

Safety

Signal Words

-Additional Signal Words.

- NOTE: The signal word NOTE provides information on operator safety and operator tips.
- IMPORTANT: The signal word IMPORTANT indicates a recommended action or a restriction that will ensure correct equipment operation and performance.

Safety



General Guidelines

Every year many unnecessary accidents occur due to improper equipment handling and a disregard for safety precautions. You, the operator, can avoid accidents by observing the precautions listed in this section.

- The operator should be a responsible adult. Do not allow persons to operate this sprayer until they have displayed a thorough understanding of sprayer safety precautions and operational use!
- All operators must also fulfill state pesticide applicator license requirements!
- Never attempt to operate this sprayer when under the influence of alcohol or drugs.
- The best defense against accidents is a careful and responsible operator.
- A chemical warning decal and an owner's manual warning decal are located on the sprayer's tank. (Figure 1). Be aware of their location. Always replace any warning or safety decals that are not legible or are missing.
- When transporting the sprayer on public roads, always follow state and local regulations regarding safety and transportation requirements. Use the necessary lights and slow moving vehicle (SMV) emblems.
- If there is any portion of this manual that you do not fully understand, please contact the original retailer of this product.



Figure 1: Chemical Warning / Read Owner's Manual Decal



Before Operation

- Carefully study and understand this owner's manual.
- Read and follow chemical manufacturer's labels, warnings, and instructions! A material safety data sheet (MSDS) should be provided by the chemical manufacturer.
- To avoid injury from chemical hazards, wear the proper protective clothing. Each chemical manufacturer's clothing requirements are listed under the "Personal Protective Equipment (PPE)" section in the chemical instructions.
- Do not wear loose-fitting clothing which may catch in moving parts.
- Never exceed the vehicle manufacturer's load rating.
- Give the sprayer a visual inspection for any worn parts, loose bolts, or other visible problems, and make the necessary repairs. See the "Maintenance Instructions" section for instructions.
- Make sure the area is clear of any people or obstructions before using the sprayer.
- Have all operators practice operating the sprayer and its attachments, using clean water only, until all persons are completely capable of safe operation.



During Operation

- Always be aware of bystanders, particularly children! Always look before moving the sprayer or the utility vehicle.
- No passengers are allowed on or in the vehicle or sprayer at anytime.
- Keep hands and body parts clear of all moving parts.
- Be aware of dangerous terrain such as holes, slopes, drop-offs, banks, rocks, and hidden hazards.
- Operate the vehicle and sprayer up and down slopes, not across.
- Allow for sprayer boom length when making turns.
- Never leave running equipment unattended!
- Remember that accidents can even happen to seasoned operators. Always take your time and follow all safety instructions.



Following Operation

- Following operation, stop the vehicle, set brakes, shut off engine, and remove ignition key.
- Store the sprayer away from human and livestock activity.
- Park the sprayer on a hard level surface
- Do not permit children to play on or around sprayer.



Pump Safety Precautions

- Never pump flammable or explosive fluids such as gasoline, fuel oil, kerosene, etc.
- NOTE: The pump may be run dry for limited periods of time without resulting in damage.
- Always disconnect the power to the pump when working on the pump. Failure to do this could result in electrical shock.

Installation

Mounting the Skid Sprayer

It is recommended to use straps (1) to secure the sprayer to the utility vehicle's bed, as shown (Figure 1).

- There are two different mounting positions for the boom mounts (Item 2) to allow for different bed lengths.
- The boom (Item 3) can be bolted at different heights to have the spray height hold out to as close to 20 inches as possible from the tip to the ground.

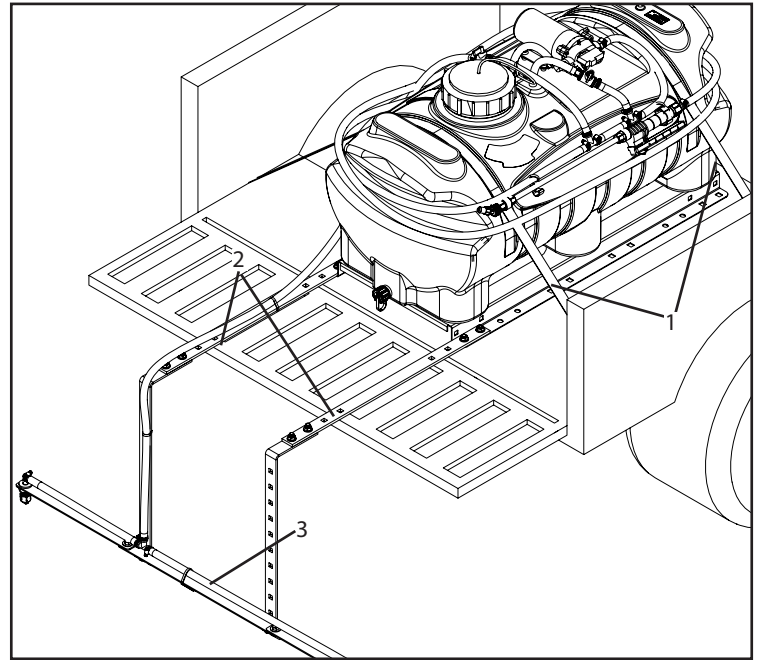

Figure 1: Skid Sprayer Mounting

Wiring Harness

1. The wiring harness needs to be connected to a DC power source (vehicle battery) or a power access point providing at least 12 volts & 10 amps of current to the ring terminals on the fuse harness (3) (Figure 2). NOTE: Make sure that the selected power source provides the adequate power requirements as stated above. Inadequate power can cause problems and performance issues with the pump.
2. Connect the red wire to the positive terminal on the vehicle's battery or other alternate power source positive terminal. Proceed to connect the black wire to the negative terminal of the vehicle's battery or a good ground source. NOTE: The fused wire harness (3) (Figure 2) can be unplugged from the switch harness (2) (Figure 2) and be left attached to the battery or power source for convenience purposes.

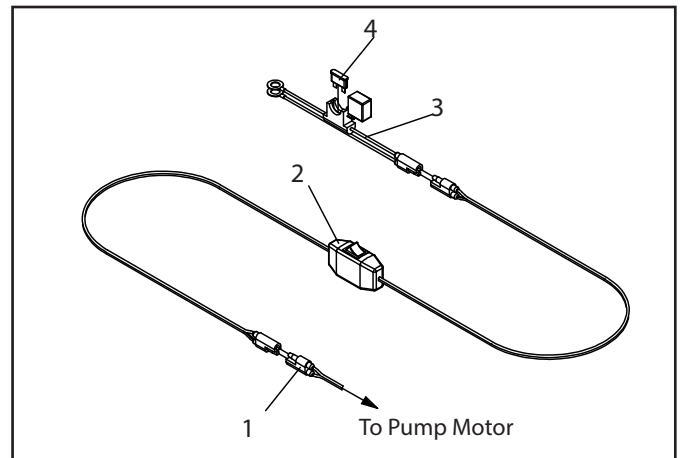

Figure 2: Wiring Harness

3. Mount the switch (2) (Figure 2) in a location that is easily accessible for operation on the vehicle. Make sure to secure the switch so that it cannot fall out of place or become entangled and cause damage. NOTE: Use caution when routing the wiring harness to avoid areas where the wires could become pinched, rubbed, or exposed to excessive heat.

Wiring Harness			
Ref #	Qty.	Part Number	Description
1	1	--	Motor Plug End
2	1	SPT-SWH-9615A-16G	Harness, Wiring 8 Ft w/ Switch
3	1	SPT-BCG-1215A-16G	Harness, Battery Connector w/15A Fuse
4	1	ATC-15	Fuse, 15 Amp Buss

Calibrating the Sprayer

When spraying with the boom, the sprayer must be calibrated to ensure proper spray coverage. Before calibrating the sprayer, it is important to familiarize yourself with the "Operating Instructions" section. The calibration process is simplified when broken down into the following steps:

1. Calculate the speed of the utility vehicle.
2. Consult the application rate charts for the desired or instructed Gallons per Acre (GPA) or Gallons per 1000 Sq. Ft.

1. Calculating the Speed

It is important to determine what speed you will be traveling at while spraying. While some utility vehicles may have speedometers, it is still recommended that speed be calculated for accuracy purposes. To determine the speed follow these four steps:

1. Measure a 200 foot or 300 foot distance on a field or a surface similar to where you will be spraying.
2. Drive the equipment and sprayer (half-full is optimal) across the measured distance at a constant rate of speed. This should be a comfortable speed for spraying.
3. Have someone measure the amount of time (in seconds) it takes to travel the measured distance. NOTE: Be sure to maintain a constant speed while measuring the time.
4. Speed can be calculated by entering your data into the equation $\text{Speed (mph)} = (\text{Distance (ft)} \times 60) / (\text{Time (seconds)} \times 88)$ or by consulting the table to the left.

NOTE: It is helpful for future references to record the exact RPM and gear used to find your speed.

Speed in MPH	Time required (seconds) to travel a distance of:	
	200 feet	300 feet
1.0	136	205
1.5	91	136
2.0	68	102
2.5	55	82
3.0	45	68
3.5	39	58
4.0	34	51
4.5	30	45
5.0	27	41
5.5	25	37
6.0	23	34
6.5	21	31
7.0	19	29

Calibrating the Sprayer

2. Application Rate Charts

The sprayer operates at a fixed pressure through the boom and spray wand. Although the pressure can be adjusted to the boom by partially opening the boom control valve (1) (Figure 1, pg 9), it is recommended that the valve is operated in full open position. Use the chart below to select your desired speed and application rate.

Boom Application Rate Chart

Tip Size	PSI	GPM of one nozzle	Gallons Per Acre (GPA)				
			2mph	3 MPH	4 MPH	5 MPH	6 MPH
TP11008VP	35	0.75	52.8	35.5	26.4	21.1	17.6
	40	0.8	56.2	37.5	28.1	22.5	18.7

Tip Size	PSI	GPM of one nozzle	Gallons per 1000 Sq. Ft				
			2mph	3 MPH	4 MPH	5 MPH	6 MPH
TP11008VP	35	0.75	1.21	0.80	0.60	0.48	0.40
	40	0.8	1.29	0.86	0.64	0.51	0.43

NOTE: Flow rates are calculated using water.

Operating Instructions

IMPORTANT: Before spraying, read this entire manual and know all safety precautions. Always take your time and be alert when operating your sprayer in order to avoid an accident.

Spraying with the Boom

1. Calibrate the sprayer using the preceding calibration instructions and chart. This will determine your speed and GPA or Gallons/1000 Sq. Ft. when spraying.
2. Fill the tank with some water in order to test for leaks.
3. Prepare the sprayer for spraying by opening the Boom Control ball valve (1) (Figure 1) in the boom supply line. It is recommended that the valve is operated in full open position. NOTE: The open position for ball valves are in line with the hose, and the closed position is perpendicular to the hose.
4. The sprayer is equipped with a Recirculation ball valve (2) (Figure 1) to aid in material agitation and pressure control. The closed position for this valve is full pressure for the boom and spray wand. NOTE: This valve should be closed when spraying with the boom.
5. Start the utility vehicle and engage the pump by turning on the power switch (2) (Figure 2, pg 5) on the wiring harness. Check the sprayer to be sure that there are no leaks in any of the hoses.
6. Test spray pattern with water on driveway or sidewalk. Each spray tip pattern should spread out to the right and left sides, rather than to the front and back of the boom. NOTE: If the spray patterns from the tips (1) (Figure 2) are hitting the sprayer, angle the tips until the spray pattern clears the sprayer. To adjust the spray tip angle, loosen spray tip cap nut (3). Align spray tip (1) and tighten cap nut (See Figure 2).
7. There should be some spray overlap between each tip and the spray patterns should be consistent. If the spray pattern is inconsistent, the tips (1) (Figure 2) may be worn out and need replaced, or there is a clog in the tip strainer (see the "Routine Maintenance" section).
8. Turn off the pump using the power switch (2) (Figure 1, pg 6) on the wiring harness.
9. Fill the tank with the correct amount of water and chemicals as is recommended for the chemical being used. **IMPORTANT:** Liquid spray material is recommended. Sprayer does not agitate wettable powders.
10. After the tank is full, close the Boom Control Valve (1) (Figure 1), engage the pump by turning on the power switch (2) (Figure 1, pg 6) and allow the water to circulate to ensure proper mixing of the chemicals and water. The

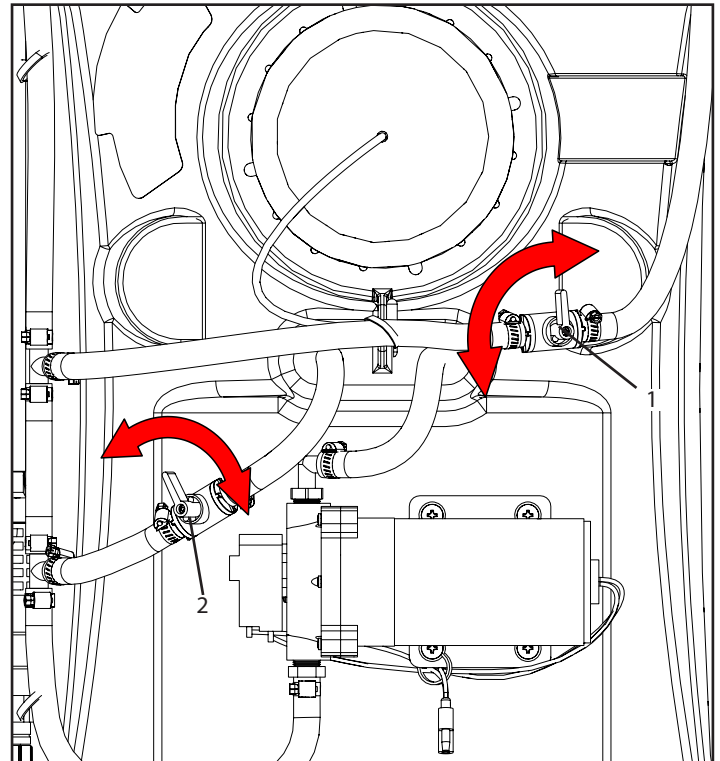

Figure 1: Boom Control Valve and Recirculation Valve

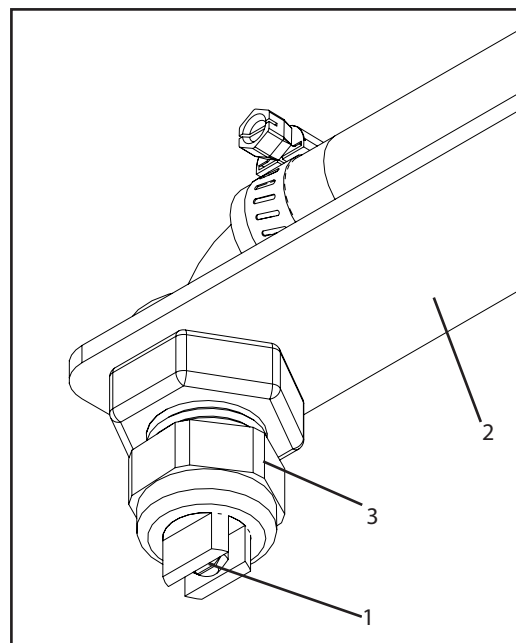

Figure 2: Boom Spray Tip

Operating Instructions

Spraying with the Boom Continued

sprayer is now ready to begin spraying.

11. Upon arriving at the spraying location, unfold the boom extensions (1) (Figure 3).
12. Engage the pump by turning on the power switch (2) (Figure 2, pg 5), open the Boom Control valve (1) (Figure 1, pg 9).
13. Spraying Tips :
 - Do not let sprayer run in one spot.
 - Do not over spray when you use weed killers.
 - Turn sprayer off during turns to avoid double spraying.
14. When the sprayer tank is empty, or you have finished spraying, turn off the sprayer with the power switch (2) (Figure 2, pg 5).

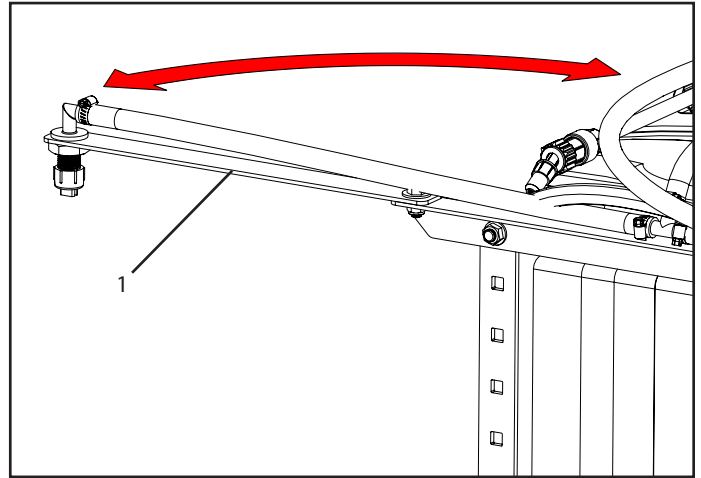

Figure 3: Boom Extension

Spraying with the Spray Gun

1. Fill the tank with some water in order to test for leaks.
2. Prepare the sprayer for spraying by closing the Boom Control valve (1) (Figure 1, pg 9) in the boom supply line.
3. The sprayer is equipped with a recirculation valve (2) (Figure 1, pg 9) to aid in material agitation and pressure control. The closed position for this valve is full pressure for the boom and spray wand. NOTE: It may be helpful to adjust the pressure when spraying with the spray wand to avoid damage to plants from excess pressure.
4. Start the utility vehicle and engage the pump by turning on the power switch (2) (Figure 2, pg 5) on the wiring harness. Check the sprayer to be sure that there are no leaks in any of the lines.
5. Turn off the pump using the power switch (2) (Figure 2, pg 5) on the wiring harness.
6. You may now fill the tank with the correct amount of water and chemicals recommended by the chemical being used.
7. After the tank is full, engage the pump by turning on the power switch (2) (Figure 2, pg 5) and allow the water to circulate to ensure proper mixing of the chemicals and water. You are now ready to begin spraying.
8. Upon arriving at the spraying location, engage the pump. Press the trigger on the spray gun to engage the gun. NOTE: The tip at the end of the gun can be turned

to adjust the spray pattern.

9. When you are ready to spray, point the gun in the desired direction and squeeze the trigger on the spray gun. The pump will automatically start when the spray gun is engaged.
10. The spray gun's liquid flow can be adjusted by turning the spray tip (1) at the end of the spray gun wand. The spray gun's trigger can also be locked in the "on" position by sliding the plastic tab (2) on the top of the trigger towards yourself (Figure 4).

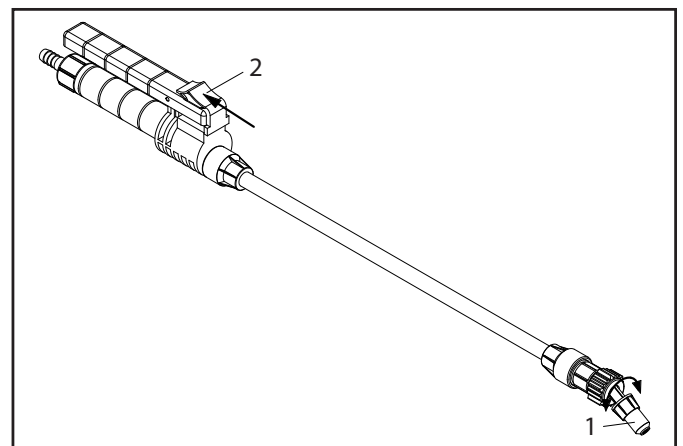

Figure 4: Spray gun

Operating Instructions

Following Operation

1. Remove tank drain cap, and empty sprayer tank. Empty remaining solution into an appropriated container for proper disposal.
2. Thoroughly rinse the sprayer of any chemical residue. It is recommended to fill the tank with at least two gallons of fresh water and engage the spray gun and boom until the system is entirely free of chemical residue. **NOTE:** Use individual containers to catch water from spray tips. Properly dispose of clean out fluid.
3. **WARNING:** Do not rinse the sprayer in an area if other humans, animals, or sensitive plants are present and could come in contact with chemical residue.
4. Spray all inside surfaces of tank with low pressure garden hose to remove any remaining solution. Rinse several times to make sure sprayer tank is clean and free of chemicals.
5. Replace drain cap and run fresh, clean water through pump, sprayer wand and all hoses thoroughly.
6. Once the tank is empty, wipe out inside of sprayer tank with a clean cloth or paper towel.
7. Fold in boom extensions, and remove sprayer from utility vehicle.
8. Store the sprayer in a location where it will be away from human or animal activity. Do not allow children to play on or near the sprayer.

Maintenance Instructions

Routine Maintenance

IMPORTANT: Perform routine maintenance on your sprayer before and after each use. Good maintenance practices will help to guard against any unnecessary sprayer breakdowns or accidents.

1. It is recommended to perform a visual and physical inspection for worn parts, loose bolts, or other visible problems. Make all necessary repairs before spraying. Contact the original retailer for instructions on ordering parts and technical help.
2. **IMPORTANT:** Rinse the pump and all components by running water through the system. Fill the tank with a sufficient amount of fresh water and engage both the spray gun and the boom. Rinsing the pump with fresh water will greatly improve the life of the pump.
3. Always follow all pump safety precautions and warnings (See page 5). Following these guidelines will help increase the longevity of the pump.
4. **Cleaning the Pump Suction Screen**
 - The suction strainer (1) (Figure 1) located on the end of suction hose should be inspected and rinsed off on a regular basis.
 - If necessary, unscrew suction screen and clean with liquid detergent and warm water.
 - If suction screen was removed, install on suction hose and position in lowest depression inside tank.

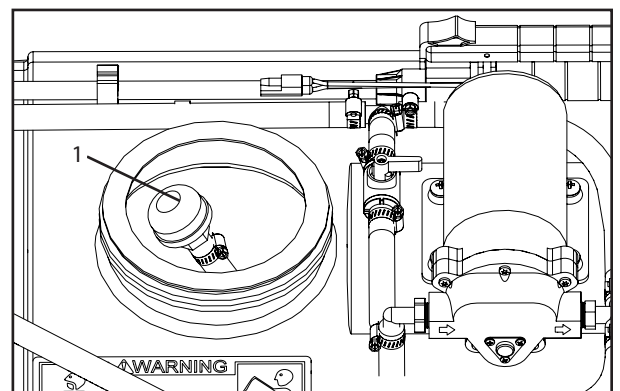

Figure 1: Checking Suction Screen

Maintenance Instructions

Routine Maintenance

5. Cleaning the spray nozzle

- Remove spray nozzle (1) (Figure 2) from sprayer.
- Disassemble filter (2) and spray tip (3). NOTE: Do not use a wire to clean opening (3) in spray tip.
- Wash filter and spray tip in a non-flammable solvent.
- Put spray tip in spray nozzle.
- Put flat side of filter in spray nozzle.
- Install assembly on sprayer and tighten nozzle.

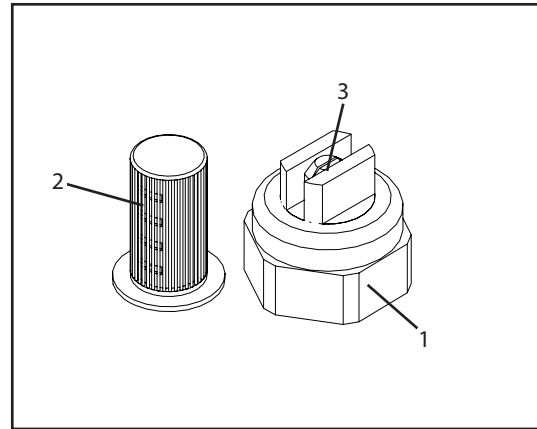

Figure 2: Spray Nozzle

NOTE: Due to normal wear, Teejet® recommends that you replace your sprayer nozzles after every spraying season. Nozzle replacement will ensure accurate spraying performance.

Winterizing your Sprayer

It is essential that you winterize your sprayer to avoid damage and allow for optimal performance. The winterization process should be performed before freezing conditions or after each season of use. Failure to winterize your sprayer will void the manufacturer's warranty and could cause damage to the sprayer.

1. Verify that the tank is empty and rinsed out. Pour 1/2 to 1 gallon of RV non-toxic antifreeze into the tank. WARNING: Do not use standard automotive antifreeze (ethylene glycol) as it can be harmful to humans, animals, crops, and the environment.
2. Engage the pump by turning on the power switch (2) (Figure 2, pg 5), then spray with the boom and the spray gun. NOTE: Be sure that the antifreeze has been pumped through the entire system including all spray nozzles.
3. Store the sprayer in a dry location away from the elements.
4. Before spraying in the spring it is recommended to flush the sprayer with fresh water to cleanse it of the antifreeze and any other buildup. NOTE: Perform a thorough inspection of all sprayer components before spraying.

IMPORTANT: Do not, under any circumstances, run any petroleum based substance (such as diesel fuel) through the sprayer. This will cause damage to sprayer components and will void the manufacturer's warranty.

Troubleshooting

As you use your sprayer, it is possible that you will encounter minor problems that can be easily fixed. The following problems and respective causes and solutions should cover most of the potential problems that you may face. If you are having problems please attempt to use this troubleshooting section to solve the problem. If you are unable to fix the problem please contact the original retailer of this product for service.

Problems/Symptoms	Possible Causes	Solutions
Low Rate of Flow	Suction Strainer is partially clogged	Remove the suction strainer and rinse
	Tip strainer is clogged	Remove tip strainer and rinse
	Pump valves are damaged/bad	Replace the valves or contact the original retailer for repairs
	Low voltage	Use a power source with at least 10 amps and 12 volts
Pump Will Not Prime	Suction line is clogged	Inspect the suction line for debris
	Suction strainer is clogged	Remove the suction strainer and rinse
	Pump is damaged from chemicals not being properly rinsed out	Contact the original retailer for service and repairs
Pump Will Not Run	Fuse is blown	Replace the fuse on the wiring harness
	Incorrect voltage	Ensure that a 10 amp, 12 volt power source is being used
	Pump pressure switch is malfunctioning	Contact the original retailer for service and repairs
No Spray Flow	Spray tip is clogged	Remove the spray tip and rinse out
	Suction strainer is clogged	Remove the suction strainer and rinse
	Nozzle tip strainer is clogged	Remove the nozzle tip strainer and rinse
Pump Pulsates On and Off	Defective pump demand switch	Contact the original retailer for service and repairs

Base Unit Breakdown

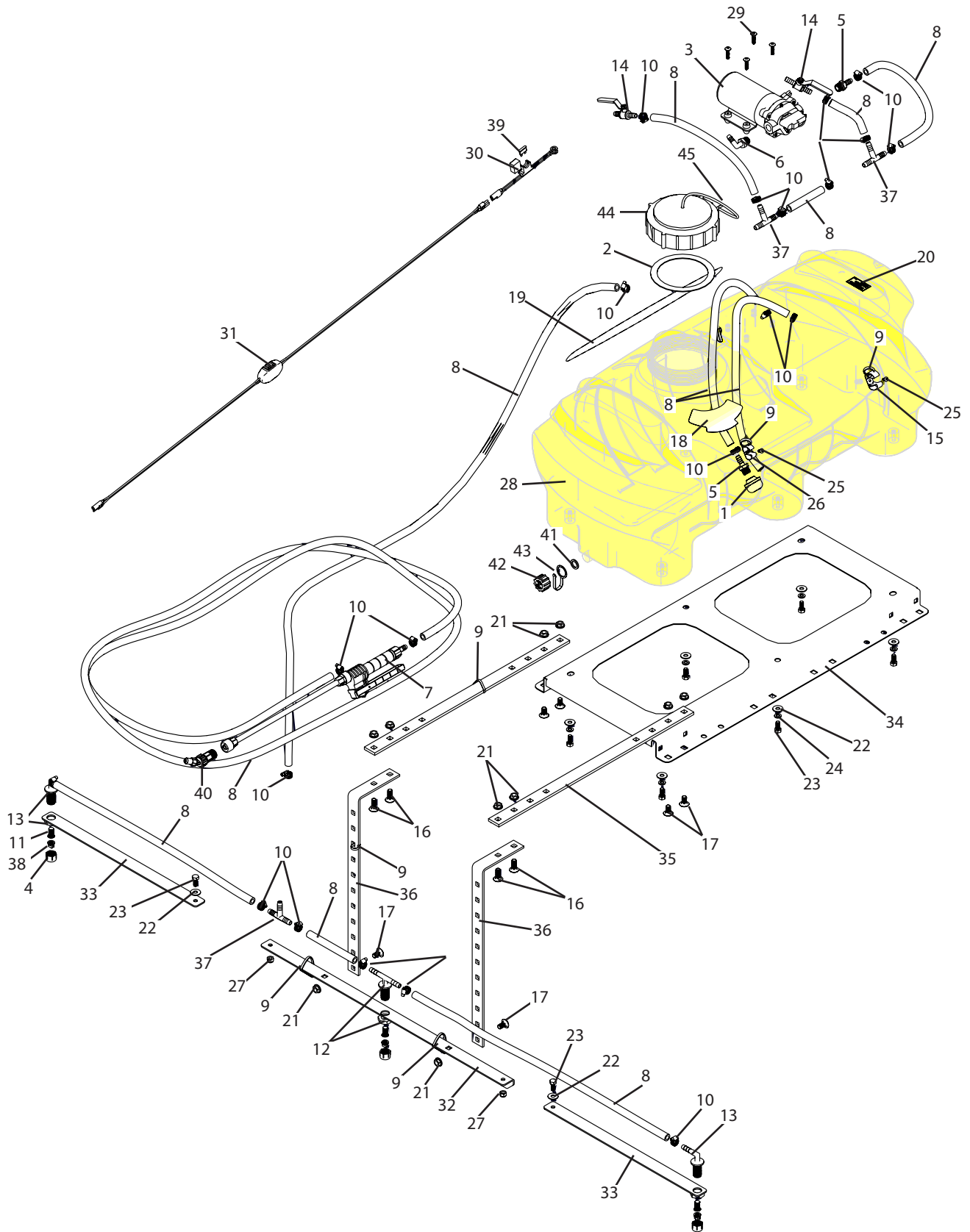

Breakdowns & Parts Lists

Base Unit Parts List

Ref#	Qty.	Part Number	Description
1	1	10416D	Strainer, Suction 3/8" FPT 40 Mesh
2	1	11042	Gasket, EPDM for 5" Lid
3	1	3323-1E1-82B	Pump, 2.2 gpm, Demand, 60psi, 3/8" FPT ports
4	3	38027	Cap, Nozzle Tip/barb 11/16-16 UNF Poly
5	2	3A3838	Adapter, Hose 3/8" MPT x 3/8" HB
6	1	3EL3838	Elbow, Hose 90° 3/8" MPT x 3/8" HB
7	1	5080015PP406	Spray Gun, TriggerJet 15" Poly Ext 3/8" HB Inlet X18 Tip
8	33 FT	6106	Hose, Clear Vinyl Reinforced 3/8" 315 PSI
9	7	618UV	Cable Tie, 6" 18 Lb UV Black
10	21	62604052	Hose Clamp, Mini 1/4" - 5/8"
11	3	8079PP50	Strainer, Tip 50 Mesh Blue Poly Body SS Screen
12	1	8120-NYB-406TD	Nozzle body, hose shank, double, 3/8", poly, 125psi
13	2	8121-NYB-406TD	Nozzle body, hose shank, elbow, 3/8", poly, 125psi
14	2	944134LF	Ball Valve, Brass, 3/8in HB
15	1	C13201	Clip, Medium Grip
16	4	CB38*1G5	Bolt, Carriage 3/8-16 x 1" Gr 5
17	6	CB38*34G5	Bolt, Carriage 3/8-16 x 3/4" Gr 5
18	1	DE210	Decal, MSDS Warning and Read Owner's Manual
19	1	DE211	Decal, LGX25
20	1	DE224	Decal, LGX25-2 Model and Revision
21	10	FN38	Nut, Flange 3/8-16
22	8	FW516	Washer, Flat 5/16"
23	8	H5C516*34	Bolt, Hex 5/16-18 x 3/4" Gr 5
24	6	LW516	Washer, Lock 5/16"
25	2	MR1024*38S	Screw, Machine Rd Hd 10-24 x 3/8" SS
26	1	N189472	Clip, Gripper 3/8" - 5/8" Zinc
27	2	NNC516	Nut, Lock Nylon 5/16-18
28	1	T1436	Tank, 25 Gallon Yellow Poly w/Lid Lanyard Outlet Cap Gasket and Tether
29	4	SBT316*1	Bolt, Stove Truss Head 10-24 x 1"
30	1	SPT-BCG-1215A-16G	Harness, Battery Connector 14G w/15A Fuse
31	1	SPT-SWH-9615A-16G	Harness, Wiring 8 Ft 14G w/ Switch
32	1	T1441	LGX25, Boom Center
33	2	T1442	LGX25, Boom Wing
34	1	T1430	LGX25-ATX25 Frame
35	2	T1433	LGX25 Skid, Extension
36	2	T1438	LGX25, Boom Mount
37	3	T38	Tee, 3/8" hose barbs, nylon
38	3	TP11008VP	Teejet spray tip, flat fan, ceramic, white
39	1	ATC-15	Fuse, 15 Amp Buss
40	1	38720PPBX18	Adjustable spray nozzle, #18
41	1	10960	Gasket, Tank Outlet Cap
42	1	19024	Cap, Tank Outlet
43	1	19025	Tether, Cap Tank Outlet
44	1	10035	Lid, Tank 5" w/ out Lanyard
45	1	10873	Lanyard, 12"

* Additional part breakdowns available.

*** Included with spray gun part# (5080015PP406).

** Included with tank part# (T1436)

Breakdowns & Parts Lists

Pump Breakdown & Parts List

Model: 3323-1E1-82B

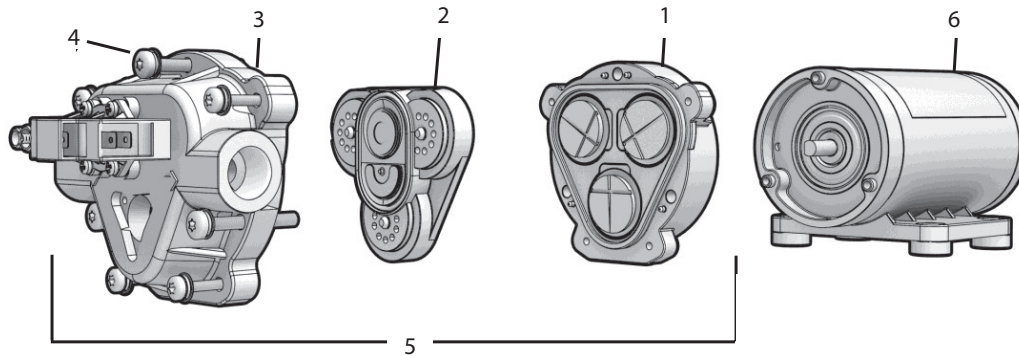

Ref #	Qty.	Part Number	Description
1	1	LHA7863-7F77	Lower Housing Assembly
2	1	VHA7863-7F77	Valve Housing Assembly
3	1	UHA7880-7F77	Upper Housing Assembly, Threaded with Pressure Switch
4	1	11-158-100	Mounting Bolt Kit
5	1	7883-7F77	Complete Pump head Assembly, Threaded with Pressure Switch
6	1	M382-S	Motor, Sealed, 2-pin Connector

CropCare[®] Limited Warranty

Model #: LGX25-2

Warranty Coverage

CropCare[®] hereby provides a Limited Three (3) Year Warranty on LGX Sprayers, manufactured by CropCare[®]. LGX Sprayers manufactured by CropCare[®] are warranted against any manufacturer's defects in any of the sprayer's components in the 36 months following the original date of purchase.

Defective components will be repaired or replaced at the discretion of the manufacturer. It is the responsibility of the purchaser to return warranted components to the manufacturer. This warranty is limited to the repair or replacement of sprayer components only. CropCare[®] is not to be held liable for incidental or consequential damages of any kind. This warranty covers the purchaser of this sprayer and any other owners who own it during the warranty period.

To retain the warranty, the sprayer must be operated and maintained as ascribed by its owner's manual. For warranty service, please have a copy of the purchase invoice available.

Warranty Is Void if:

1. The sprayer has been subjected to, in the opinion of CropCare[®], negligent handling, misuse, an accident or if the instructions in the owner's manual were not completely followed.
2. The sprayer's components have been altered in any manner or repairs have taken place with unapproved parts.
3. The sprayer and its components were subject to freezing or freezing conditions. The sprayer must have been winterized as per the maintenance instructions to retain the warranty.
4. A non-compatible chemical was used and/or if the sprayer operator failed to rinse all chemical residue out of the sprayer's components after use.
5. A petroleum-based, oil-based, or flammable product was used and caused damage to the pump, tank, hoses, or any other component.

Getting Warranty Service

All warranty claims must be made through the original retailer. All warranty claims must be submitted with an invoice or a proof of purchase that denotes the purchase date and place of purchase. If you have any questions or comments concerning this warranty, please contact the original retailer.

Ordering Parts

Please contact the original retailer to order replacement parts for your product.

CROPCARE

Manufactured by PBZ LLC
A Paul B Zimmerman Inc. Company
www.CropCareEquipment.com